

Model: SH240

Data

Type: Hermetic scroll compressors

Producer: Danfoss-Maneurop

Series: SH

Model: SH240

Technical data

Displacement [m ³ /h]:	39,6
Swept volume [cm ³ /rev]:	227,6
RPM [min ⁻¹]:	2900
Weight [kg]:	108
Oil charge [dm ³]:	6,7
Oil type:	160SZ
Maximum system test pressure low side / high side:	30/45
Maximum number of starts without softstart [1/h]:	12
Refrigerant charge limit [dm ³]:	13,5
Sound power [dB]:	82
Refrigerant:	R410A

Connections

	<u>milimeters</u>	<u>inches</u>
Suction connection with supplied sleeve:	41	1 5/8"
Discharge connection with supplied sleeve:	35	1 3/8"

Model: SH240

Capacity

R410A

Cooling capacity [W]

$t_c \setminus t_e$	-25	-20	-15	-10	-5	0	5	10	15
20	25 912	31 929	39 037	47 371	57 070	68 269	81 105	-	-
25	24 366	30 269	37 206	45 313	54 727	65 586	78 025	92 182	-
30	22 789	28 548	35 285	43 135	52 237	62 726	74 739	88 413	103 885
35	21 182	26 769	33 276	40 841	49 600	59 690	71 247	84 409	99 313
40	-	24 932	31 181	38 430	46 817	56 479	67 552	80 173	94 478
45	-	23 040	29 001	35 906	43 892	53 096	63 655	75 705	89 383
50	-	-	26 738	33 269	40 825	49 542	59 558	71 008	84 030
55	-	-	-	30 522	37 618	45 819	55 262	66 083	78 419
60	-	-	-	-	34 272	41 928	50 769	60 931	72 552
65	-	-	-	-	-	37 871	46 081	55 555	66 432

Power input [W]

$t_c \setminus t_e$	-25	-20	-15	-10	-5	0	5	10	15
20	8 642	8 641	8 638	8 658	8 727	8 870	9 113	-	-
25	9 721	9 731	9 721	9 718	9 745	9 830	9 997	10 272	-
30	10 878	10 910	10 905	10 889	10 886	10 923	11 025	11 217	11 526
35	12 136	12 200	12 210	12 192	12 170	12 171	12 219	12 340	12 559
40	-	13 622	13 658	13 649	13 619	13 593	13 598	13 659	13 800
45	-	15 196	15 270	15 280	15 252	15 212	15 185	15 196	15 271
50	-	-	17 065	17 106	17 092	17 048	16 999	16 972	16 990
55	-	-	-	19 148	19 158	19 121	19 062	19 007	18 980
60	-	-	-	-	21 472	21 453	21 394	21 322	21 262
65	-	-	-	-	-	24 063	24 017	23 939	23 855

Current [A]

$t_c \setminus t_e$	-25	-20	-15	-10	-5	0	5	10	15
20	22.01	21.94	21.79	21.61	21.46	21.38	21.43	-	-
25	22.82	22.85	22.78	22.66	22.54	22.47	22.50	22.69	-
30	23.76	23.89	23.90	23.83	23.74	23.68	23.69	23.84	24.17
35	24.88	25.11	25.19	25.18	25.12	25.06	25.06	25.17	25.44
40	-	26.57	26.73	26.76	26.73	26.68	26.66	26.73	26.93
45	-	28.32	28.55	28.63	28.63	28.58	28.54	28.57	28.71
50	-	-	30.71	30.85	30.87	30.83	30.77	30.75	30.82
55	-	-	-	33.46	33.51	33.47	33.39	33.33	33.33
60	-	-	-	-	36.60	36.56	36.46	36.35	36.28
65	-	-	-	-	-	40.16	40.03	39.88	39.74

Model: SH240

Capacity

Mass flow [kg/h]

$t_c \setminus t_e$	-25	-20	-15	-10	-5	0	5	10	15
20	453.12	556.69	675.33	811.48	967.59	1 146.13	1 349.53	-	-
25	445.21	549.68	669.21	806.25	963.26	1 142.69	1 347.00	1 578.63	-
30	435.93	541.10	661.34	799.08	956.80	1 136.93	1 341.95	1 574.29	1 836.41
35	425.20	530.89	651.63	789.89	948.12	1 128.77	1 334.30	1 567.16	1 829.80
40	-	518.95	640.01	778.60	937.15	1 118.13	1 323.98	1 557.17	1 820.14
45	-	505.21	626.40	765.12	923.81	1 104.92	1 310.91	1 544.23	1 807.34
50	-	-	610.72	749.38	908.01	1 089.06	1 295.00	1 528.27	1 791.32
55	-	-	-	731.29	889.67	1 070.48	1 276.17	1 509.19	1 772.00
60	-	-	-	-	868.71	1 049.08	1 254.34	1 486.93	1 749.31
65	-	-	-	-	-	1 024.80	1 229.43	1 461.39	1 723.15

C.O.P. [W/W]

$t_c \setminus t_e$	-25	-20	-15	-10	-5	0	5	10	15
20	3.00	3.70	4.52	5.47	6.54	7.70	8.90	-	-
25	2.51	3.11	3.83	4.66	5.62	6.67	7.80	8.97	-
30	2.09	2.62	3.24	3.96	4.80	5.74	6.78	7.88	9.01
35	1.75	2.19	2.73	3.35	4.08	4.90	5.83	6.84	7.91
40	-	1.83	2.28	2.82	3.44	4.15	4.97	5.87	6.85
45	-	1.52	1.90	2.35	2.88	3.49	4.19	4.98	5.85
50	-	-	1.57	1.94	2.39	2.91	3.50	4.18	4.95
55	-	-	-	1.59	1.96	2.40	2.90	3.48	4.13
60	-	-	-	-	1.60	1.95	2.37	2.86	3.41
65	-	-	-	-	-	1.57	1.92	2.32	2.78

Operating conditions: superheating: 11.1 K, subcooling: 8.3 K

t_c - Condensing temperature [°C]

t_e - Evaporating temperature [°C]

Application range

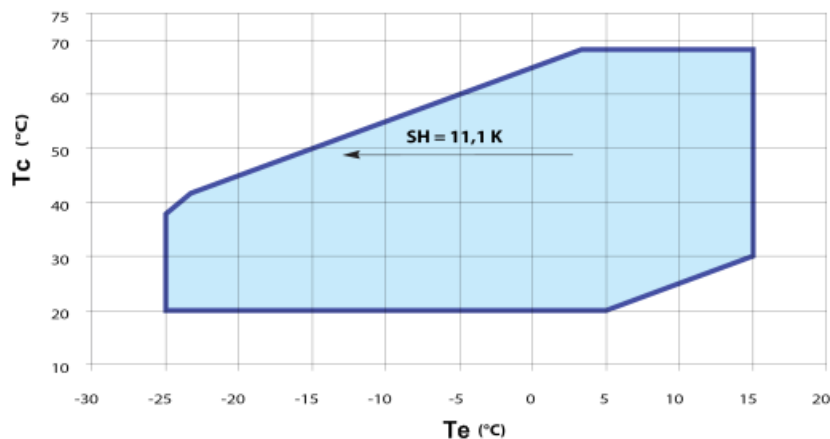

Model: SH240

Dimensions

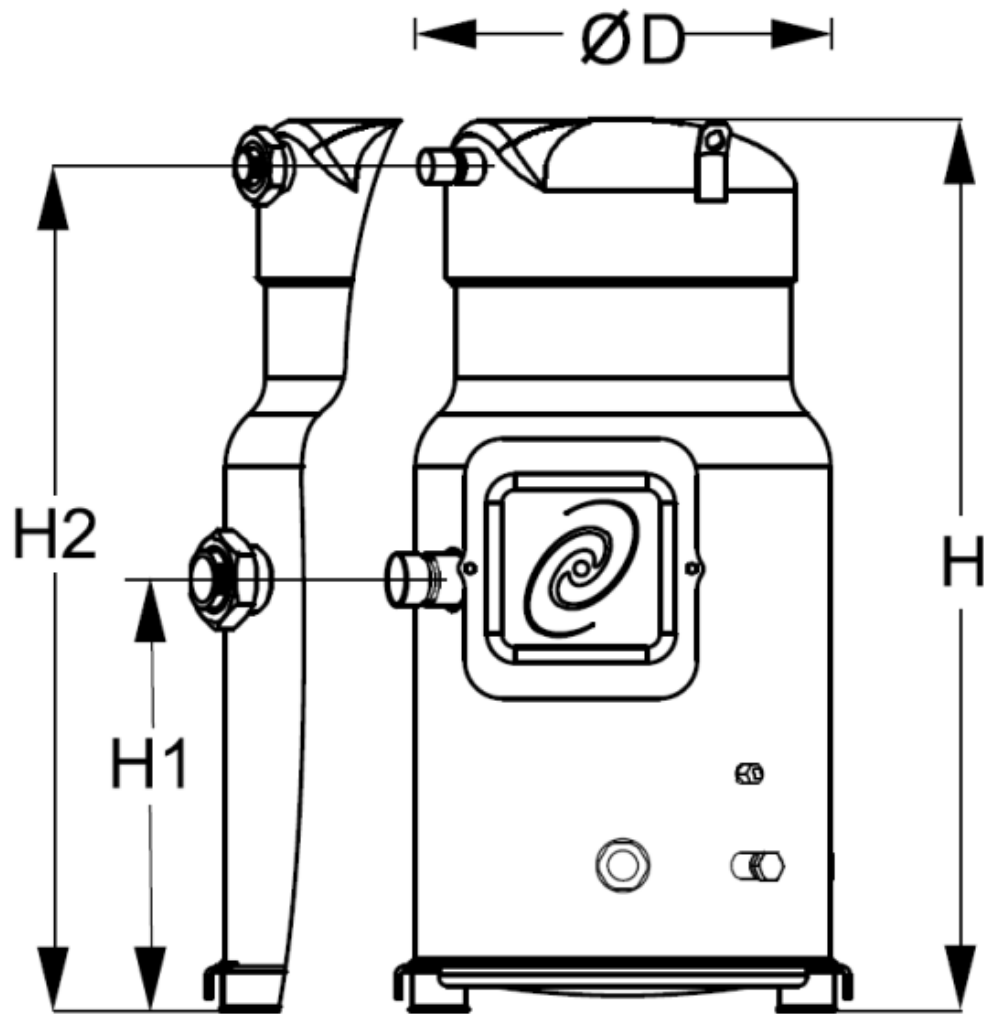

D [mm]: 317,8
H [mm]: 682
H1 [mm]: 330,5
H2 [mm]: 646,5

Model: SH240

Image



Single phase power supply

Motor voltage code: 4
Power supply: 400V/3/50Hz
Maximum Continuous Current (MCC) [A]: 42,1

Wiring diagram with pump-down cycle

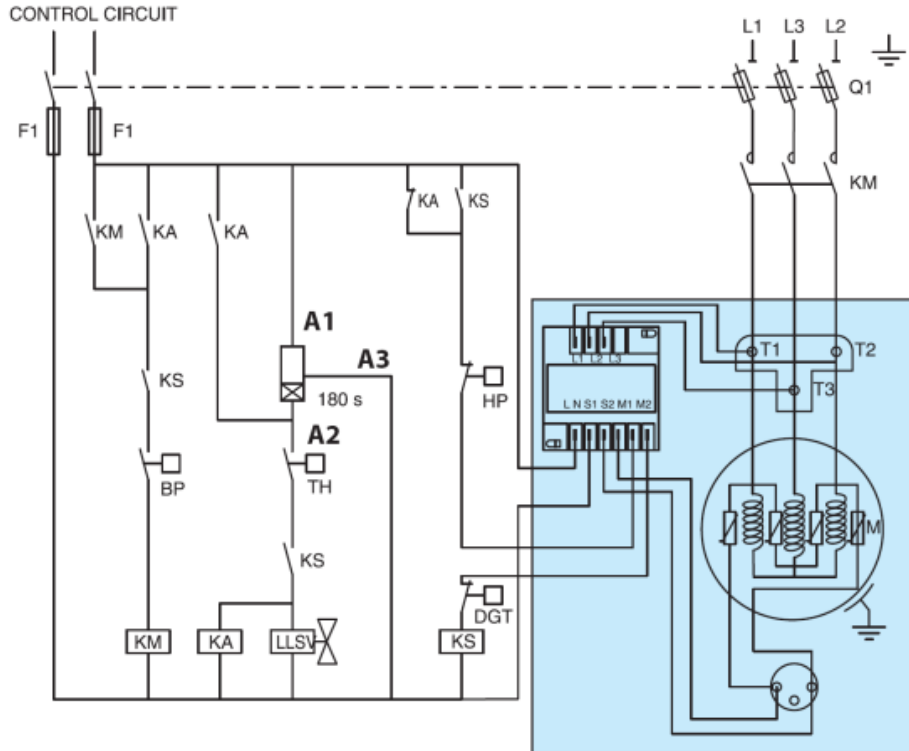

- TH: Control device
- 180 s: Optional short cycle timer (3min) 5 pts
- KA: Control relay
- LLSV: Liquid Line Solenoid valve
- KM: Compressor contactor
- KS: Safety lock out relay
- BP: Pump-down control and low pressure switch
- HP: High pressure safety switch
- Q1: Fused disconnect
- F1: Fuses / S: External overload protection
- F2: External overload protection
- M: Compressor's engine
- thM: Motor safety thermostat
- DGT: Discharge gas thermostat
- MPM: Motor Protection Module
- S: Thermistor chain

Wiring diagram without pump-down cycle

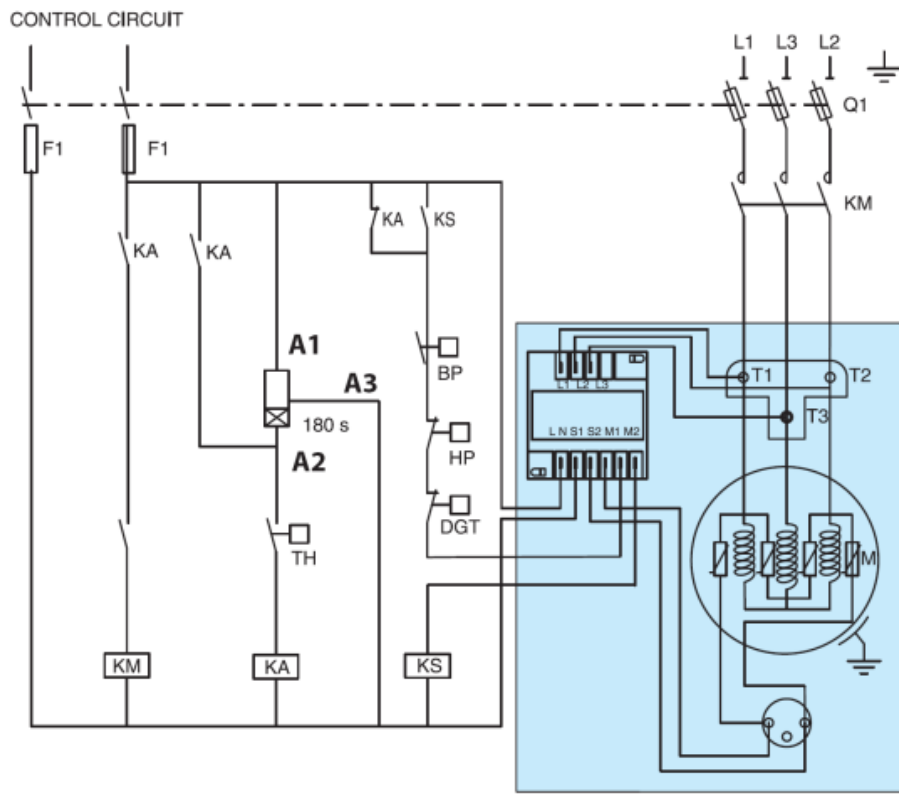

- TH: Control device
- 180 s: Optional short cycle timer (3min) 5 pts
- KA: Control relay
- LLSV: Liquid Line Solenoid valve
- KM: Compressor contactor
- KS: Safety lock out relay
- BP: Pump-down control and low pressure switch
- HP: High pressure safety switch
- Q1: Fused disconnect
- F1: Fuses / S: External overload protection
- F2: External overload protection
- M: Compressor's engine
- thM: Motor safety thermostat
- DGT: Discharge gas thermostat
- MPM: Motor Protection Module
- S: Thermistor chain